

ZAXIS-6 series

HITACHI

Reliable solutions

SHORT REACH FRONT

A P P L I C A T I O N & A T T A C H M E N T



ZAXIS135us

Model Code	ZX135US-6
Engine Rated Power	78.5 kW (ISO 14396)
Operating Weight	15 700 - 16 100 kg

DEMAND PERFECTION

The ZX135US-6 short reach front excavator is ideal for use when space is limited and height restricted, such as tunnelling projects, underground excavation and demolition work. It can be used with larger attachments than the standard model, and has greater bucket digging force than larger 20-tonne class machines.

Like all Zaxis-6 medium excavators, it is equipped with innovative technology, and operates reliably and efficiently with the lowest possible cost of ownership.



Exceptional productivity

Large bucket cylinder and enhanced hydraulic circuit for use with larger attachments.



Extended reach

New front attachment design has increased working range.



Excellent versatility

Short boom and arm ideal for confined spaces.



Added protection

Bucket cylinder guard and reinforced bucket linkage.





Enhanced safety

Two lifting brackets ensure safe and stable lifting.



Increased durability

Improved side piping for hydraulics.



Outstanding stability

Heavier counterweight ensures stability.



Increased utility

Short swing radius is ideal for tight spaces.



Excellent efficiency

HIOS IV reduces total hydraulic loss.



Improved performance

Superior hydraulic circuit designed exclusively by Hitachi.





The short boom and arm is perfect for small spaces.



Brackets on the upper structure for safe lifting.



Enhanced hydraulic circuit for use with larger attachments.

EXCEPTIONAL PERFORMANCE

When space is limited, you can rely on the ZX135US-6 short reach front excavator to operate with a high level of productivity and safety. More compact than a conventional excavator, it offers a superior digging performance as it is designed and built to use attachments suitable for larger 20-tonne machines.

Expanded working range

Thanks to its short boom and arm, this model is an ideal fit for job sites where space is limited. The opening angle of the boom and arm has also been widened, which means the arm can be raised higher in work spaces with low height clearance.

Superior digging performance

The enhanced hydraulic circuit enables the ZX135US-6 short reach front excavator to be used with larger attachments and buckets than the standard model. It also has greater digging force than larger 20-tonne class machines, resulting in a superior digging performance.

Stable lifting

The heavier counterweight increases the lifting capacity of the ZX135US-6 short reach front when it is used with larger attachments. It has also been designed with two lifting brackets on the upper structure (and one on the boom), for safe and stable transport at the job site – either lowering into position on sites below ground level or lifting up to higher floors using a crane.









Cylinder guard provides additional protection.



Front top guard complies with demolition specifications.



Reinforced under covers help to prevent damage.

OUTSTANDING DURABILITY

Challenging projects such as tunnelling, demolition and underground excavation require the most reliable and durable construction machinery. Hitachi has developed the ZX135US-6 short reach front machine using durable components and incorporating additional safety features to achieve high levels of availability.

Durable components

The bucket cylinder guard has been strengthened for the Zaxis-6 model to offer greater protection against potential damage. The ZX135US-6 short reach front excavator has the same reinforced bucket link as the ZX210LC-6, and this reduces the load on the bucket cylinder.

Added protection

The ZX135US-6 short reach front excavator has reinforced under covers, and the side piping has been improved

and straightened along the short boom. To cope with the low back pressure required by attachments, it has fewer elbow parts and hoses.

Enhanced safety

The cab of the ZX135US-6 short reach front excavator complies with industry requirements for demolition machines. This includes the OPG level II front and head guard, and the strengthened glass in the front window.



SPECIFICATIONS

ENGINE

Model	Isuzu AR-4JJ1X
Type	4-cycle water-cooled, common rail direct injection
Aspiration	Variable geometry turbocharged, intercooled, cooled EGR
Aftertreatment	DOC and SCR system
No. of cylinders	4
Rated power	
ISO 14396	78.5 kW at 2 000 min ⁻¹
ISO 9249, net	74.9 kW at 2 000 min ⁻¹
SAE J1349, net	74.9 kW at 2 000 min ⁻¹
Maximum torque	375 Nm at 1 800 min ⁻¹
Piston displacement	2.999 L
Bore and stroke	95.4 mm x 104.9 mm
Batteries	2 x 12 V / 58 Ah

HYDRAULIC SYSTEM

Hydraulic Pumps

Main pumps	2 variable displacement axial piston pumps
Maximum oil flow	2 x 117 L/min
Pilot pump	1 gear pump
Maximum oil flow	33.6 L/min

Hydraulic Motors

Travel	2 variable displacement axial piston motors
Swing	1 axial piston motor

Relief Valve Settings

Implement circuit	34.3 MPa
Swing circuit	32.3 MPa
Travel circuit	34.3 MPa
Pilot circuit	3.9 MPa
Power boost	36.3 MPa

Hydraulic Cylinders

	Quantity	Bore	Rod diameter
Boom	2	105 mm	70 mm
Arm	1	120 mm	85 mm
Bucket	1	120 mm	85 mm

UPPERSTRUCTURE

Revolving Frame

D-section frame for resistance to deformation.

Swing Device

Axial piston motor with planetary reduction gear is bathed in oil. Swing circle is single-row. Swing parking brake is spring-set/hydraulic-released disc type.

Swing speed	13.7 min ⁻¹
Swing torque	33 kNm

Operator's Cab

Independent spacious cab, 1 005 mm wide by 1 675 mm high, conforming to ISO* Standards.

* International Organization for Standardization

UNDERCARRIAGE

Tracks

Tractor-type undercarriage. Welded track frame using selected materials.

Side frame welded to track frame. Lubricated track rollers, idlers, and sprockets with floating seals.

Track shoes with triple grousers made of induction-hardened rolled alloy.

Heat-treated connecting pins with dirt seals. Hydraulic (grease) track adjusters with shock-absorbing recoil springs.

Numbers of Rollers and Shoes on Each Side

Upper rollers	1
Lower rollers	7
Track shoes	44
Track guards	2

Travel Device

Each track driven by 2-speed axial piston motor.

Parking brake is spring-set/hydraulic-released disc type.

Automatic transmission system: High-Low.

Travel speeds	High : 0 to 5.5 km/h
	Low : 0 to 3.3 km/h

Maximum traction force	117 kN
------------------------------	--------

Gradeability	70% (35 degree) continuous
--------------------	----------------------------

SOUND LEVEL

Sound level in cab according to ISO 6396 LpA 69 dB(A)

External sound level according to ISO 6395 and

EU Directive 2000/14/EC LwA 99 dB(A)

SERVICE REFILL CAPACITIES

Fuel tank	220.0 L
Engine coolant	21.0 L
Engine oil	17.0 L
Swing device	3.2 L
Travel device (each side)	4.0 L
Hydraulic system	155.0 L
Hydraulic oil tank	60.0 L
DEF/AdBlue® tank	13.0 L

WEIGHTS AND GROUND PRESSURE

Operating Weight and Ground Pressure

		ZAXIS 135US	
Boom type		Monoblock	
Shoe type	Shoe width	kg	kPa
Triple grouser	500 mm	15 700	49
	600 mm	15 900	42
	700 mm	16 100	36

* Including 0.65 m³ (ISO heaped) bucket weight (550 kg) and counterweight (4 300 kg).

Basic Machine Weight and Overall Width

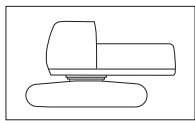

Excluding front end attachment, fuel, hydraulic oil and coolant etc. Including counterweight.

ZAXIS 135US

		ZAXIS 135US	
Shoe type	Shoe width	Weight	Overall width
Triple grouser	500 mm	12 600 kg	2 490 mm
	600 mm	12 800 kg	2 590 mm
	700 mm	13 000 kg	2 690 mm

Components Weight

	Weight
Counterweight	4 300 kg
Boom	790 kg
Arm (with bucket cylinder, A-link and B-link)	1 000 kg
Bucket 0.65 m ³	550 kg

BUCKET AND ARM DIGGING FORCE

	ZAXIS 135US
Bucket digging force* ISO	99 kN
Bucket digging force* SAE : PCSA	86 kN
Arm crowd force* ISO	61 kN
Arm crowd force* SAE : PCSA	59 kN

* At power boost

SPECIFICATIONS

WORKING RANGES: MONOBLOCK BOOM

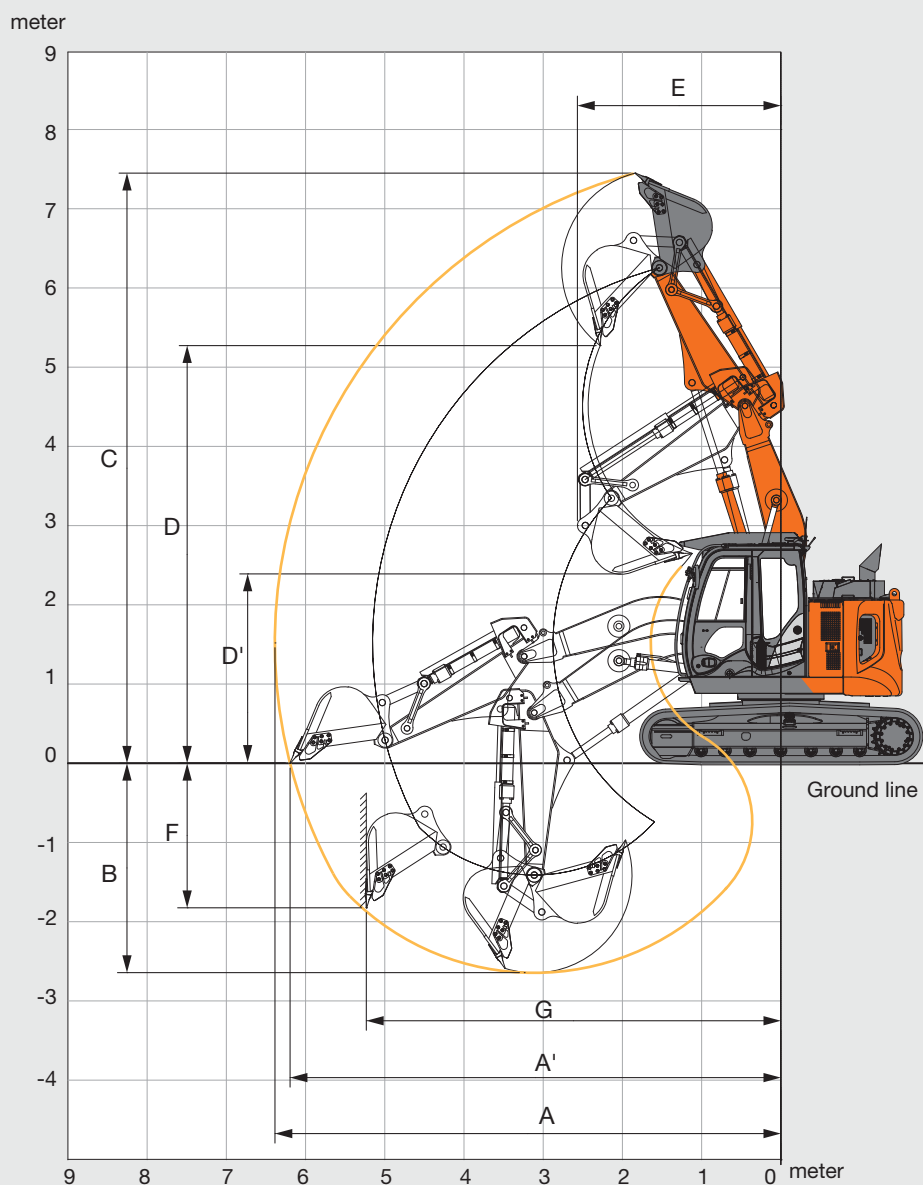

Unit: mm

	ZAXIS 135US
	Monoblock boom
Arm length	2.05 m
A Max. digging reach	6 390
A' Max. digging reach (on ground)	6 200
B Max. digging depth	2 640
C Max. cutting height	7 450
D Max. dumping height	5 270
D' Min. dumping height	2 390
E Min. swing radius	2 570
F Max. vertical wall digging depth	1 820
G Reach at max. vertical wall digging depth	5 230

Excluding track shoe lug

DIMENSIONS

MONOBLOCK BOOM

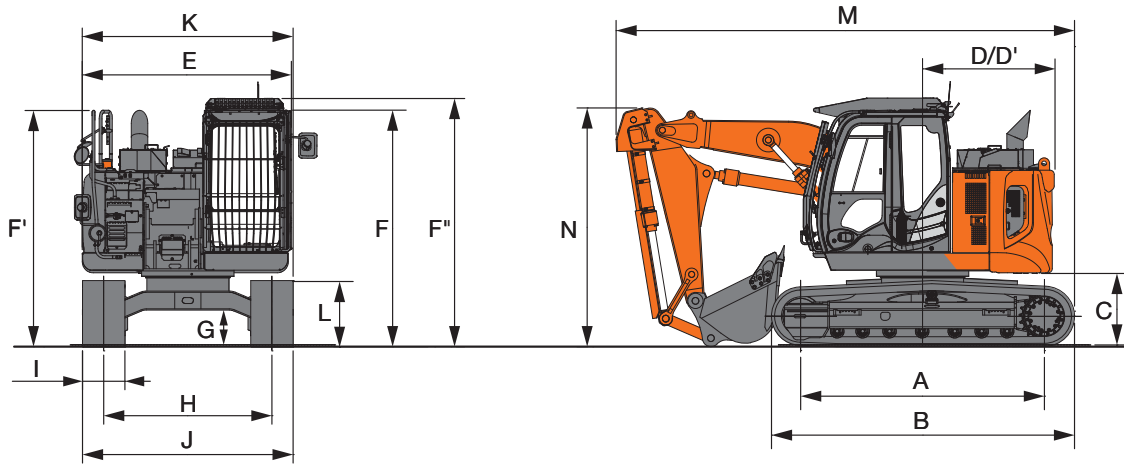

Unit: mm

	ZAXIS 135US
A Distance between tumbler	2 880
B Undercarriage length	3 580
* C Counterweight clearance	840
D Rear-end swing radius	1 600
D' Rear-end length	1 600
E Overall width of upperstructure	2 480
F Overall height of cab	2 790
F' Overall height of handrail	2 870
F'' Overall height of handrail (on cab)	2 940
* G Min. ground clearance	410
H Track gauge	1 990
I Track shoe width	G 500
J Undercarriage width	2 490
K Overall width	2 490
*1 L Track height with triple grouser shoes	790
M Overall length	5 410
N Overall height of boom	2 820

*1 Excluding track shoe lug

*2 The dimensions asterisked are for transport pin position.

G: Triple grouser shoe

LIFTING CAPACITIES

- Notes:
1. Ratings are based on ISO 10567.
 2. Lifting capacity does not exceed 75% of tipping load with the machine on firm, level ground or 87% full hydraulic capacity.
 3. The load point is the center-line of the bucket pivot mounting pin on the arm.
 4. *Indicates load limited by hydraulic capacity.
 5. 0 m = Ground.

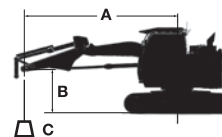

- A: Load radius
B: Load point height
C: Lifting capacity

For lifting capacities, subtract bucket and quick hitch weight from lifting capacities.

ZX135US

Rating over-front Rating over-side or 360 degrees Unit : kg

Conditions	Load point height m	Load radius				At max. reach		
		3.0 m		4.5 m				meter
Boom 3.00 m Arm 2.05 m Counterweight 4 300 kg Shoe 500 mm	4.5	*5 940	*5 940			*5 680	4 250	4.14
	3.0	*6 760	*6 760	*5 410	3 640	4 670	3 090	4.92
	1.5	*8 580	6 770	5 320	3 480	4 230	2 780	5.15
	0 (Ground)	*8 950	6 350	*5 180	3 360	*4 480	2 950	4.91
	-1.5	*6 410	6 390			*5 390	5 120	3.44

EQUIPMENT

● : Standard equipment

○ : Optional equipment

ENGINE

Aftertreatment device	●
Air cleaner double filters	●
Alternator 50 A	●
Auto idle system	●
Auto shut-down control	●
Cartridge-type engine oil filter	●
Cartridge-type fuel main filter	●
Cold fuel resistance valve	○
DEF/AdBlue® tank inlet strainer and extension filler	●
DEF/AdBlue® tank with ISO magnet adapter	●
Dry-type air filter with evacuator valve (with air filter restriction indicator)	●
Dust-proof indoor net	●
ECO/PWR mode control	●
Electrical fuel feed pump	●
Engine oil drain coupler	●
Expansion tank	●
Fan guard	●
Fuel cooler	●
Fuel pre-filter with water separator	●
Isolation-mounted engine	●
Maintenance free pre-cleaner	○
Radiator, oil cooler and intercooler	●

HYDRAULIC SYSTEM

Auto power lift	●
Control valve with main relief valve	●
Extra port for control valve	●
Full-flow filter	●
High mesh full flow filter with restriction indicator	○
Hose rupture valve for boom	●
Pilot filter	●
Power boost	●
Suction filter	●
Variable relief valve for breaker & crusher	●
Work mode selector	●

CAB

All-weather sound suppressed steel cab	●
AM-FM radio	●
Ashtray	●
Auto control air conditioner	●
AUX function lever (Breaker assist)	●
AUX terminal and storage	●
Cigarette lighter 24 V	●
CRES V (Center pillar reinforced structure) cab	●
Drink holder with hot & cool function	●
Electric double horn	●
Engine shut-off switch	●
Equipped with reinforced, tinted (green color) glass windows	●
Evacuation hammer	●
Floor mat	●
Footrest	●
Front window washer	●
Glove compartment	●
Hot & cool box	●
Intermittent windshield wipers	●
Key cylinder light	●
Laminated round glass window	○
OPG front guard Level II (ISO10262) compliant cab	○
OPG top guard Level I (ISO10262) compliant cab	●
OPG top guard Level II (ISO10262) compliant cab	○
Pilot control shut-off lever	●
Power outlet 12 V	○
Rain guard	○
Retractable seat belt	●
ROPS (ISO12117-2) compliant cab	●
Rubber radio antenna	●
Seat :air suspension seat with heater	●
Seat adjustment part : backrest, armrest, height and angle, slide forward / back	●
Short wrist control levers	●
Sun visor (front window/side window)	○
Transparent roof with slide curtain	●
Windows on front, upper, lower and left side can be opened	●
2 speakers	●
4 fluid-filled elastic mounts	●

MONITOR SYSTEM

Alarms: overheat, engine warning, engine oil pressure, alternator, minimum fuel level, hydraulic filter restriction, air filter restriction, work mode, overload, SCR system trouble, etc	●
Alarm buzzers: overheat, engine oil pressure, overload, SCR system trouble	●
Display of meters: water temperature, hour, fuel rate, clock, DEF/AdBlue® rate	●
Other displays: work mode, auto-idle, glow, rearview monitor, operating conditions, etc	●
32 languages selection	●
Side view monitor	●

LIGHTS

Additional boom light with cover	●
Additional cab roof front lights	●
Additional cab roof rear lights	○
Rotating lamp	○
2 working lights	●

UPPER STRUCTURE

Batteries 2 x 58 Ah	●
Battery disconnect switch	●
Body top handrail	●
Counterweight 4 300 kg	●
Electric fuel refilling pump with auto stop and filter	●
Fuel level float	●
Hydraulic oil level gauge	●
Lockable fuel refilling cap	●
Lockable machine covers	●
Lockable tool box	●
Platform handrail	●
Rear view camera	●
Rear view mirror (right & left side)	●
Side view camera	●
Skid-resistant plates and handrails	●
Swing parking brake	●
Undercover	●

UNDERCARRIAGE

Bolt-on sprocket	●
Reinforced track links with pin seals	●
Shoe: 500 mm triple grouser	●
Track undercover	●
Travel direction mark on track frame	●
Travel motor covers	●
Travel parking brake	●
Upper and lower rollers	●
1 track guard (each side) and hydraulic track adjuster	○
2 track guards (each side) and hydraulic track adjuster	●
4 tie down brackets	●

FRONT ATTACHMENTS

Welded bucket link A	●
Centralized lubrication system	●
Dirt seal on all bucket pins	●
Flanged pin	●
HN bushing	●
Reinforced resin thrust plate	●
Welded bucket link A with welded hook	○
Bucket cylinder guard	●

ATTACHMENTS

Accessories for 2 speed selector	●
Additional pump (30 L/min)	●
Assist piping	●
Attachment basic piping	●
Breaker and crusher piping	●
Parts for breaker and crusher	●
Pilot accumulator	○

MISCELLANEOUS

Global e-Service	●
Onboard information controller	●
Standard tool kit	●

Prior to operating this machine, including satellite communication system, in a country other than a country of its intended use, it may be necessary to make modifications to it so that it complies with the local regulatory standards (including safety standards) and legal requirements of that particular country. Please do not export or operate this machine outside the country of its intended use until such compliance has been confirmed. Please contact your Hitachi dealer in case of questions about compliance.

These specifications are subject to change without notice. Illustrations and photos show the standard models, and may or may not include optional equipment, accessories, and all standard equipment with some differences in color and features. Before use, read and understand the Operator's Manual for proper operation.

